

peakDetect - Pulse Monitoring Multi-Tool

Innovative Pulse Monitoring

peakDetect is an innovative measurement tool for the precise monitoring of ultra-short lasers. It is a key tool for quality management and predictive maintenance, potentially saving downtime costs and helping to plan necessary service in advance.

peakDetect is a single device without moving parts. It measures at the same time the average power, beam pointing, nonlinear efficiency and temperature. These measurements also yield pulse quality as a new unique monitoring parameter as well as the peak power as additional values.

The compact and robust design makes peakDetect ideal for incorporation into laser systems or production lines and as a portable service tool.

Solide State Laser Monitored over a 48 Hour Period

The comparison of measurement results obtained with the peakDetect and various standard measurement tools over 48 hours shows excellent agreement of trends and small variations of the derived laser parameters.

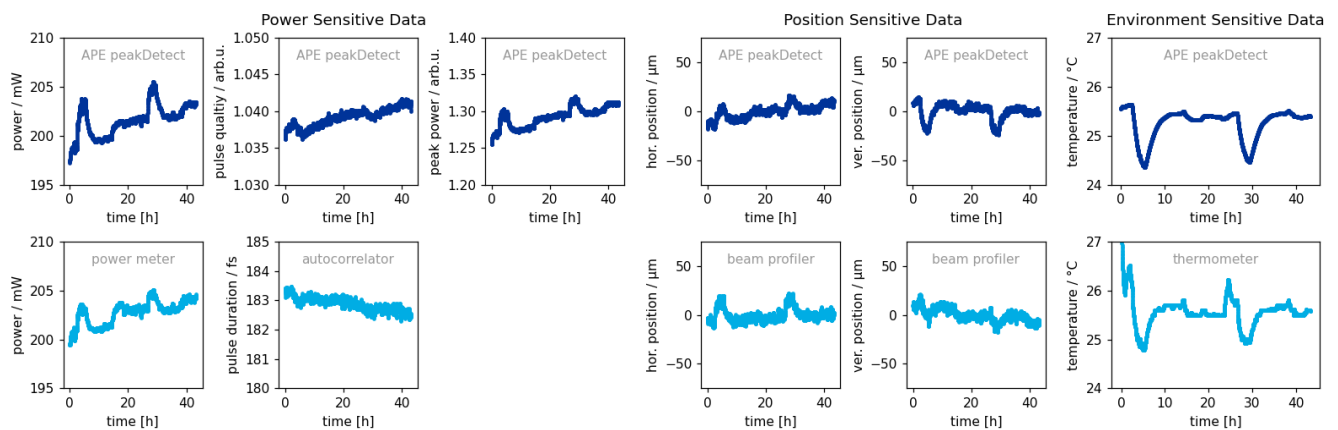

peakDetect Specifications

Applications

- Laser pulse performance monitoring, e.g. for laser production, micro-machining
- Laser-medical diagnostics and calibration, e.g. for ophthalmology
- Predictive maintenance (Industry 4.0), Laser quality management

Specifications

Wavelength Range	700 ... 1100 nm; Optimized for 1000 ... 1100 nm (e.g. fiber laser); 500 ... 550 nm (e.g. SHG of fiber laser); Other wavelengths to be discussed
Pulse Width Range	Femtoseconds, picoseconds; typically 50 fs ... 10 ps
Repetition Rate	1 kHz ... 2 MHz (with automatic repetition rate measurement) > 2 MHz with manual entry of laser repetition rate Other specifications to be discussed
Input Polarization	Linear / any orientation
Response Time / Latency time	< 5 ms
Beam Pointing Sensitivity	Accuracy < 5 μ m, Resolution < 1 μ m
Aperture	2.2 mm or customized
Computer Interface	USB, Serial, Fieldbus, Custom
Power Supply	via USB or custom
Dimensions	Small footprint for machine integration, customization possible
Directly Measured Values	Repetition rate (measured up to 2 MHz or manual entry) Average power Beam position (Pointing) Non-linear efficiency
Derived Values	Peak power Pulse quality Pulse duration

OEM Integration

APE helps you to customize your individual peakDetect monitoring system. Starting with your specific laser parameters and objectives, we support you each step of the way, towards implementing a peakDetect solution for your application. Demo units are available on request.

Pulse Quality Monitoring with APE's Autocorrelators

Pulse quality monitoring is also possible using APE's autocorrelator technology. Depending on your requirements, either peakDetect technology or autocorrelation technology may be advantageous. For a more detailed technical discussion do not hesitate to contact us.

Appendix Technical Drawings

All Dimensions in mm

peakDetect

- Peak power monitoring
- Custom dimensions possible

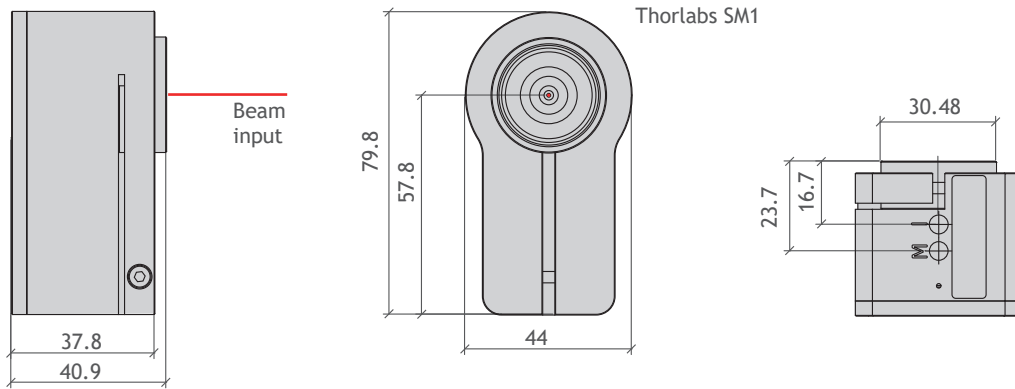

Contact

APE Angewandte Physik & Elektronik GmbH
Plauener Str. 163-165 | Haus N | 13053 Berlin | Germany
T: +49 30 986 011-30 F: +49 30 986 011-333
E: sales@ape-berlin.de www.ape-berlin.de