

HarmoniXX Select

Combined Solution for Pulse Picking & Second Harmonic Generation

Pulse Picking and SHG with HarmoniXX Select SHG

- HarmoniXX Select is the combination of two well-known APE products in one box: Adjusting the repetition rate by pulse picking (*pulseSelect*) + second harmonic wavelength conversion (*HarmoniXX SHG*) of modelocked lasers.
- The on-board pulse picker with its low dispersive design is developed for requirements associated with ultrashort pulse laser technology.
- The integrated second harmonic generator features frequency doubling of the picked input laser beam. With its flexible design, the HarmoniXX Select SHG can be adapted to Ti:Sa lasers or other broadly tuneable lasers, such as Coherent Discovery or Spectra Physics Insight.



At a Glance

- For input wavelengths between 660 ... 1320 nm
- Easy motorized operation of SHG wavelengths in the range of 330 ... 660 nm
- Adjustable output repetition rate from single-shot up to 40 MHz
- Pulse picking with superior pulse contrast ratio
- External trigger: Single-shot up to 3 MHz

HarmoniXX Select

Specifications

Input Laser Specification

Input Wavelength Range	680 ... 1080 nm (e.g. TiSa) or 660 ... 1320 nm
Input Repetition Rate	72 ... 81 MHz (to be specified with 0.5 MHz accuracy at the time of order; other rep. rates on request)
Input Power Max.	5 W
Polarization	Horizontal, linear

Output Picked SHG

Wavelength Range	340 ... 540 nm or 330 ... 660 nm (depending on input wavelength)
Contrast Ratio	100,000:1 for non-adjacent pulses 3000:1 for adjacent pulses; at 400 nm with division ratio 20
Combined Conversion Efficiency	17.5% at 400 nm and division ratio 20 for Chameleon Ultra II / Vision II / Chameleon Discovery NX; 15% at 400 nm and division ratio 20 for Insight X3
Repetition Rate	Single-shot to 40 MHz (based on 80 MHz input repetition rate)
Polarization	Vertical, linear

Note: SHG function only available in combination with pulse picker. SHG operation not available with unpicked pulses due to power constraints.

Output Picked Fundamental

	Output fundamental only, or simultaneous with SHG possible
Wavelength Range	680 ... 1080 nm or 660 ... 1320 nm
Contrast Ratio	500:1 for non-adjacent pulses 75:1 for adjacent pulses; at 800 nm with division ratio 20
Conversion Efficiency	50% at 800 nm and division ratio 20
Repetition Rate	Single-shot to 40 MHz (based on 80 MHz input repetition rate)
Polarization	Horizontal, linear

Further Specifications

Division Ratio Picker	2 ... 260,000 (integer values) or external trigger
External Trigger	TTL; Single-shot up to 3 MHz
SHG Motorization	Phase matching angle set to factory calibrated values

HarmoniXX Select

Specifications

Dimensions

Optical Head	587 mm x 189 ... 221 mm x 406 mm (W x H x D)
Control Box 1 Picker	270 mm x 205 mm x 315 mm (W x H x D)
Control Box 2 SHG	205 mm x 130 mm x 130 mm (W x H x D)

Drawings

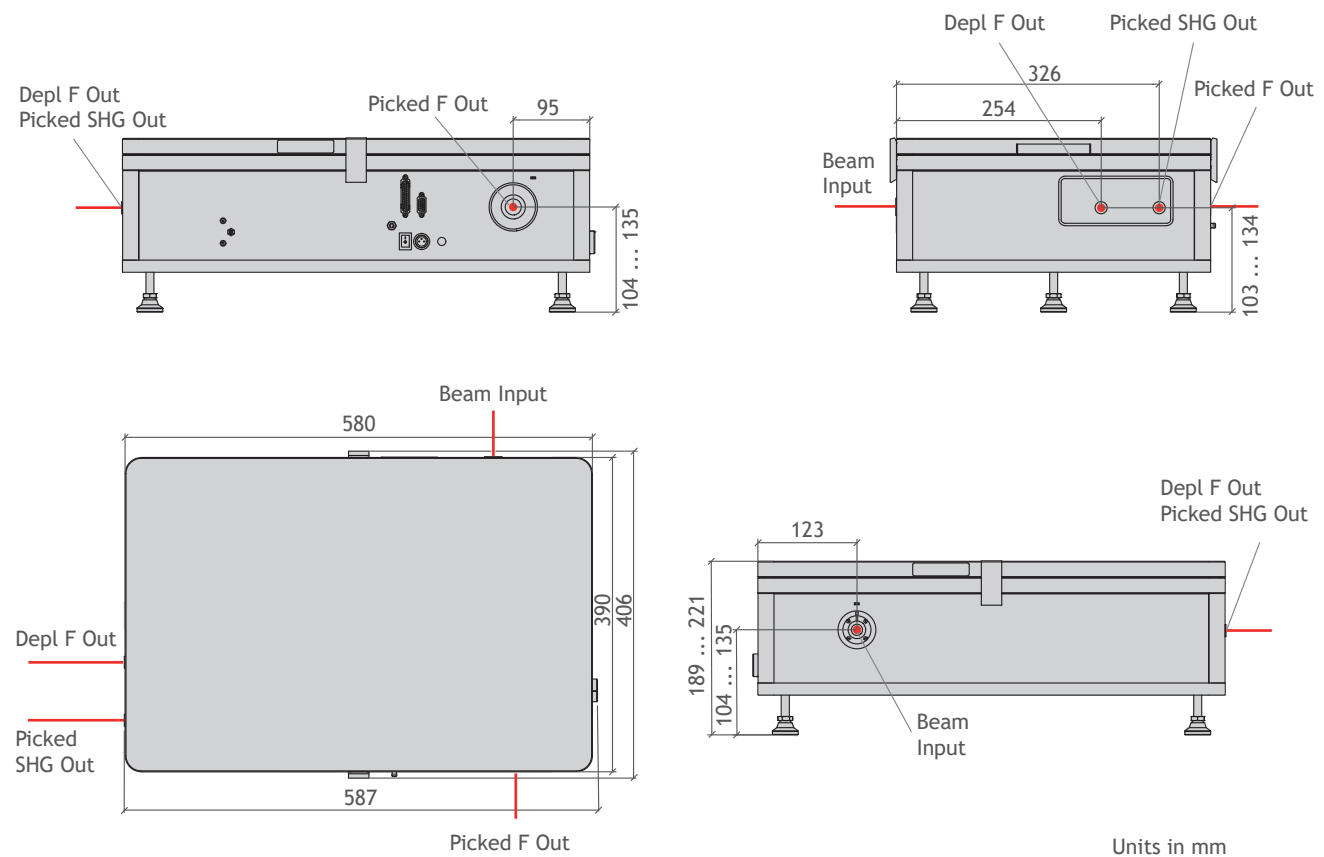

APE GmbH

Plauener Str. 163-165 | Haus N | 13053 Berlin | Germany
 T: +49 30 986 011-30 F: +49 30 986 011-333
 E: sales@ape-berlin.de
 www.ape-berlin.de