

LEVANTE IR

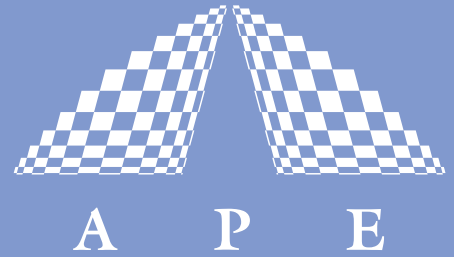

PICOSECOND-OPO

Levante IR is one out of the series of synchronously pumped picosecond-OPOs by APE.



Due to the use of a small and robust modelocked Nd:VANADATE laser as pump source **Levante IR** is compact and cost efficient. It allows the generation of ps-pulses with small bandwidth at high output power in the IR range. The pump- and OPO-pulses are intrinsically jitter free.

The system utilizes periodically poled crystals as gain medium. Wavelength tuning is achieved by temperature tuning of multiple gratings crystals.

Ultrafast Pulse Diagnostics

Wavelength Conversion

Pulse Management

Acousto-optics

Your Partner in Ultrafast

TECHNICAL DATA

Wavelength range (signal)	1450 ... 1920 nm
Output power (signal)	> 1.0 W (typically 1.5 W) @ 5 W pump > 2.0 W (typically 3.0 W) @ 10 W pump
Bandwidth	typically 0.6 nm @ 1600 nm
Pulse duration	~ 8 ps @ 7 ps pump
Typical time bandwidth product	1.5 times transform limit
Pulse repetition rate	76 MHz
Idler wavelength range (optional)	2.4 ... 4.0 μm
Idler output power (optional)	> 350 mW (typically 500 mW) @ 5 W pump > 650 mW (typically 1000 mW) @ 10 W pump

APE Levante IR is delivered with a spectrometer included

Available also for 532 nm pump: **Levante Emerald**

DIMENSIONS (in mm)

Control Electronics (W*L*H): 267 x 312 x 180

Optical unit:

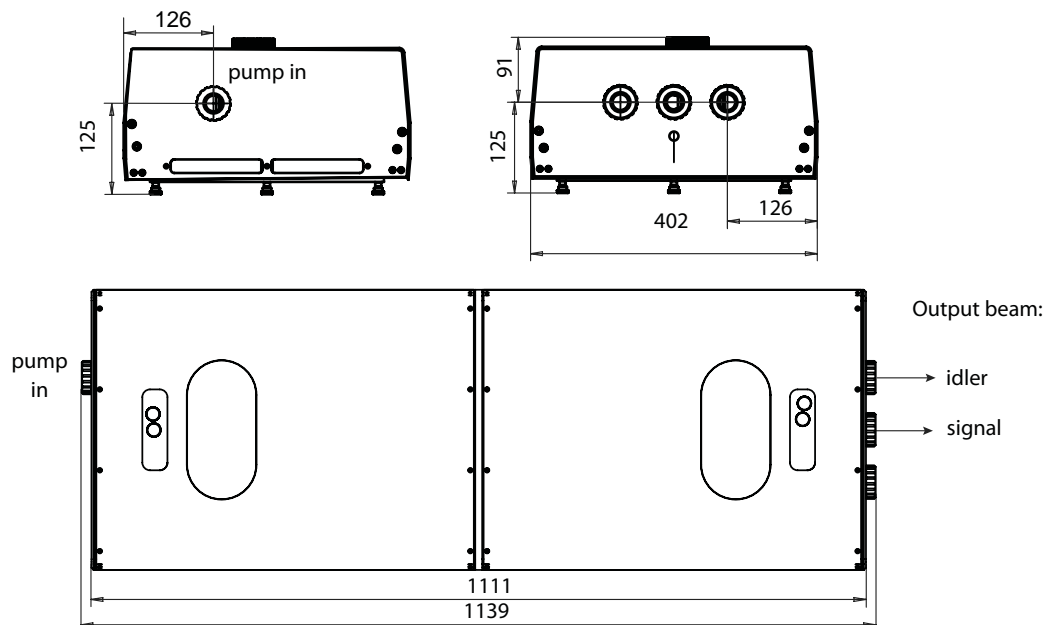

Distributors

see APE website www.ape-berlin.com

APE GmbH Plauener Straße 163-165 Haus N / 13053 Berlin Germany
Phone +49.30.986.01130 Fax +49.30.986.011333 / Web www.ape-berlin.com Email ape@ape-berlin.de

APE follows a policy of continued product improvement. Therefore, specifications are subject to change without notice.