

A P E

CAVITY DUMPER KIT

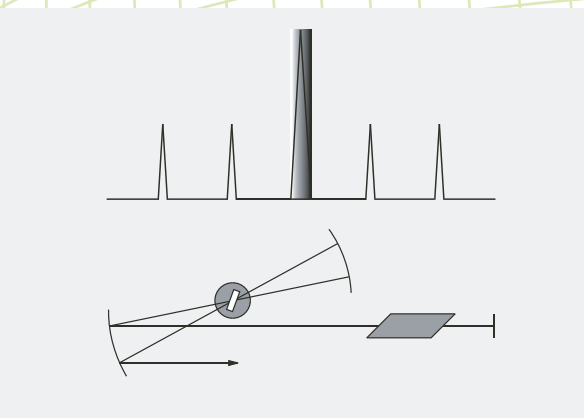

The Cavity Dumper Kit is an acoustooptical switch that is integrated in the cavity of a modelocked laser system for the reduction of the system's pulse repetition rate. Unlike with pulse pickers the intracavity operation increases the pulse energy to a multiple of the energy that is reached by the normal modelocked pulses of the system. This makes it particularly relevant for nonlinear optical processes like SHG and THG

The Cavity Dumper Kit consists of an acoustooptical Bragg cell to be integrated in the laser cavity and the PulseSwitch control electronics. As an option APE offers a mounting-kit for holding the Bragg cell. In parallel it provides all the necessary tools for adjusting the modulator.

Out of a seed input signal with the repetition rate of the modelocked system the control electronics generate the RF carrier frequency for the Bragg cell. An internal frequency divider allows for division rates between 1:20 and 1:5000 of the seed frequency (optional: 1:2 ... 1:260000). External triggering and therefore single pulse operation is possible, too. The phase of the RF signal is fine tuned by a phase shifter as a preposition for using the cavity dumper in double pass operation.

Generation of powerful laser pulses

Fast risetimes

Tunable phase shift

Suitable for a variety for different Ti:Sa-, Ion- and dye lasers as well as other laser systems

Ultrafast Pulse Diagnostics

Wavelength Conversion

Pulse Management

Acoustooptics

Your Partner in Ultrafast

CAVITY DUMPER KIT

SPECIFICATIONS

Modulator	
Material	fused silica
Required beam diameter	approx. 50 μm
Wavelength range	500 ... 1000 nm, Brewster configuration ¹⁾
Diffraction efficiency	> 50 % ²⁾
RF Driver	
Seed frequency (f_{seed}) ⁴⁾	50 ... 85 MHz (to be specified with ± 0.5 MHz accuracy at time of order)
Output repetition rate	single shot ... 3 MHz externally triggered $f_{\text{seed}}/20 \dots f_{\text{seed}}/5000$ with internal divider ($f_{\text{seed}}/260000$ optional)
Carrier frequency	350 ... 425 MHz ³⁾
Electronical pulse rise time	2 ns
Electronical pulse timing jitter	< 50 ps
RF Phase shift tuning range	> 180°

1) others optional

3) synchronized to seed frequency

2) single pass at 800nm, 4MHz (varying with wavelength and repetition rate)

4) synchronization signal with the laser repetition rate from a fast photodiode is required

DIMENSIONS

Control Electronics (W*L*H in mm)

267 x 312 x 180

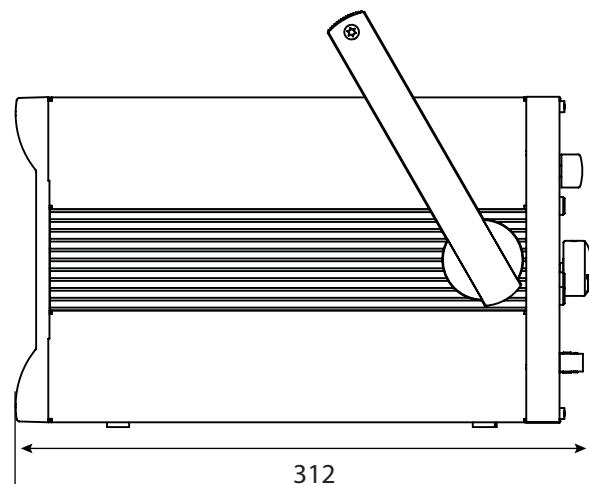
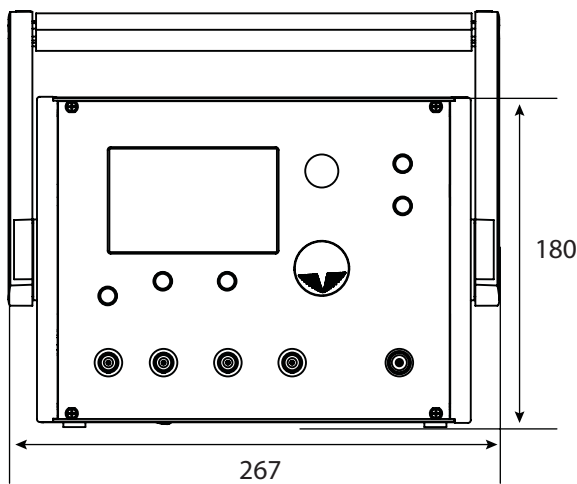

Bragg cell (in mm):

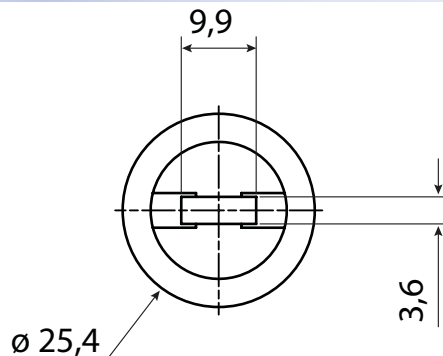
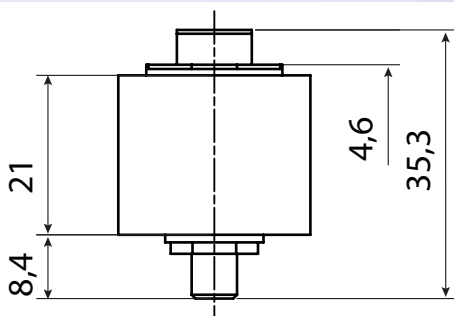

Distributors
see APE website www.ape-berlin.com

APE GmbH Plauener Straße 163-165 Haus N / 13053 Berlin Germany
Phone +49.30.986.01130 Fax +49.30.986.011333 / Web www.ape-berlin.com Email ape@ape-berlin.de

APE follows a policy of continued product improvement. Therefore, specifications are subject to change without notice.