

Mini

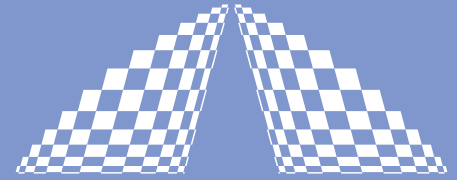

A P E

AUTOCORRELATOR

The **Mini** is a compact, interferometer based autocorrelator for measuring the pulse width of fs and ps laser systems with any repetition rate > 500 Hz. It is available for different wavelength ranges, easy to adjust and to use.

The wavelength range is chosen at the time of order and then fixed for the individual device. For in the field interchangeable wavelength ranges, please see our autocorrelator **PulseCheck**.



Femtosecond resolution

All-reflective optics

Measurement of background free and interferometric autocorrelation functions

Display of width of autocorrelation function

Very compact and robust design

Data transfer via RS232 / USB

Ultrafast Pulse Diagnostics

Wavelength Conversion

Pulse Management

Acoustooptics

Your Partner in Ultrafast

Mini

SPECIFICATIONS

Scan ranges	150 fs ... 15 ps
Measurable pulse width	50 fs ... 3.5 ps
Scan rate	~ 10 Hz
Linearity of position signal	Better 1% of actual scan range
Sensitivity ¹⁾	$10^{-4} W^2$
Wavelength ranges	VIS I 420 ... 550 nm
	VIS II 540 ... 750 nm
	NIR 700 ... 1100 nm
	IR 1000 ... 1600 nm
Input polarization	Linear / horizontal
Laser repetition rate	Depending on optics set
	PMT > 250 kHz PD > 300 Hz (low repetition rate optional)
Interaction	Collinear / non-collinear
Power supply	95 ... 240 V, 50 ... 60 Hz, 8 W
Readout	Monochrome graphical display
Outputs	Delay: analog 0 ... 10 V (monitoring on an external oscilloscope)
	Signal: analog 0 ... 10 V (monitoring on an external oscilloscope)
	USB and RS232 serial interface
Input	Trigger: TTL, f < 10 kHz

¹⁾Sensitivity is defined as average power times peak power of the incident pulses $P_{AV} * P_{Peak}$

OPTIONS

- Fiber input
- Short pulse optics
- Windows control software
- Input polarisation rotator

DIMENSIONS (in mm)

Control electronics (W x H x D) 210 x 144 x 125

Optical unit:

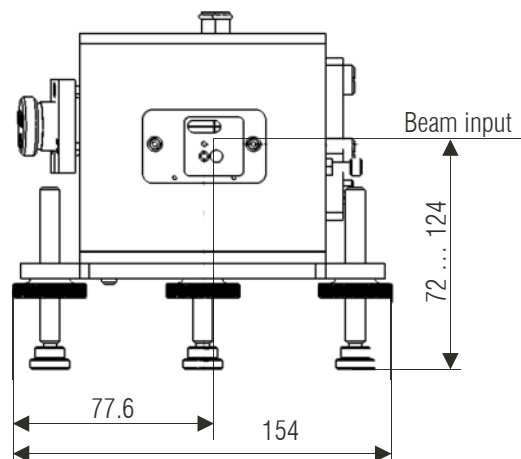
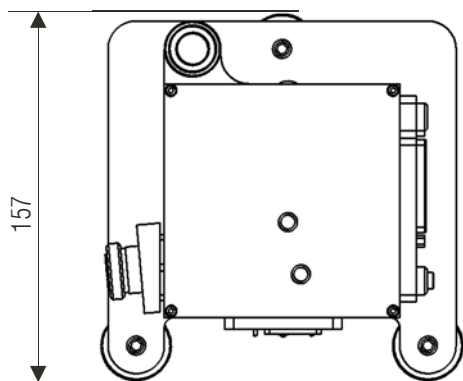

Distributors
see APE website www.ape-berlin.com

APE GmbH Plauener Straße 163-165 Haus N / 13053 Berlin Germany
Phone +49.30.986.01130 Fax +49.30.986.011333 / Web www.ape-berlin.com Email ape@ape-berlin.de

APE follows a policy of continued product improvement. Therefore, specifications are subject to change without notice.